

A

B

C

D

E

F

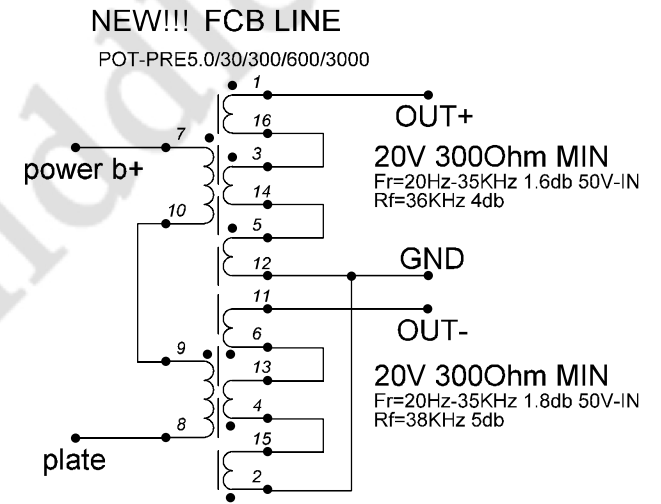
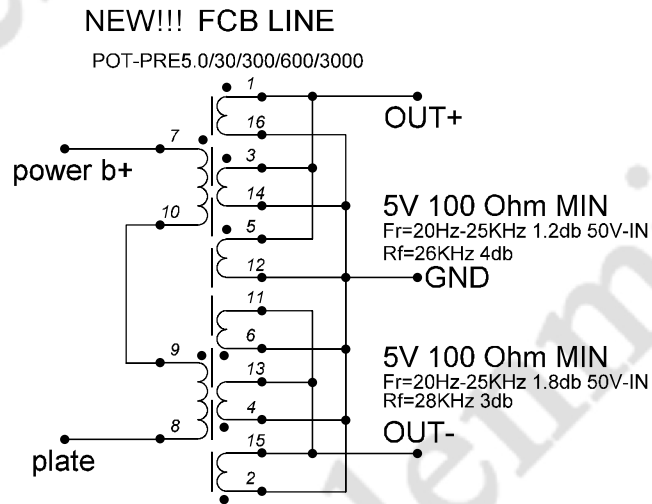
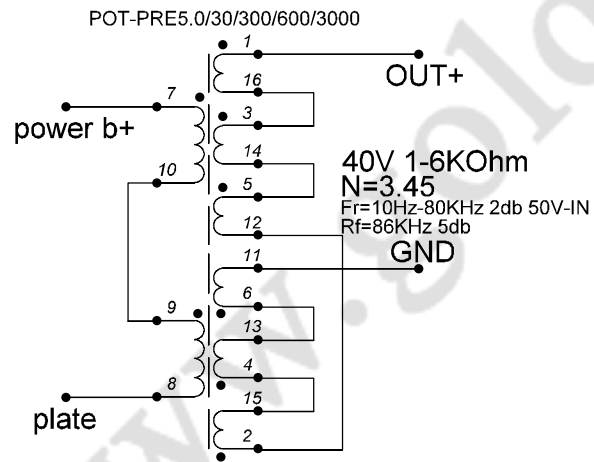
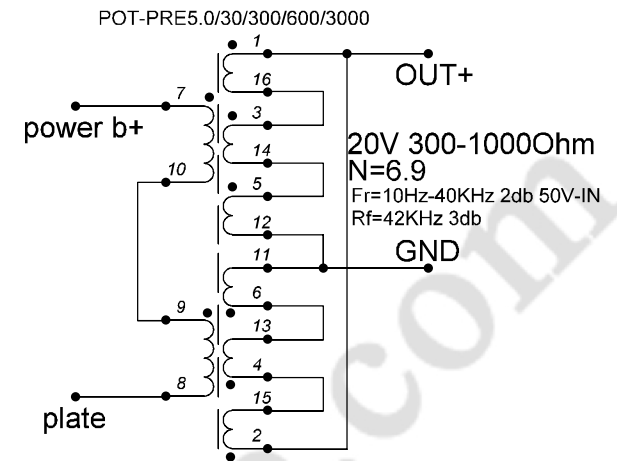
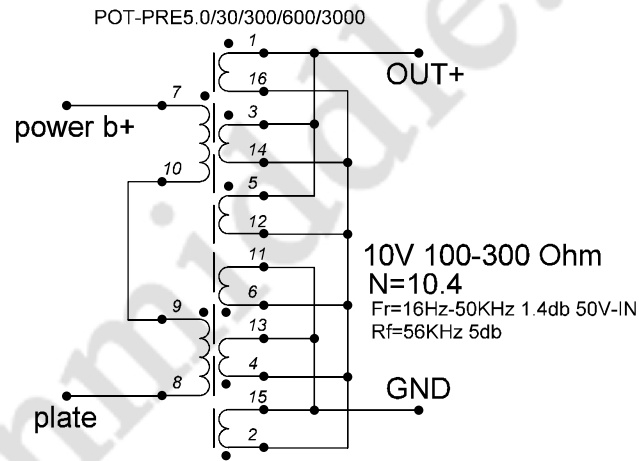
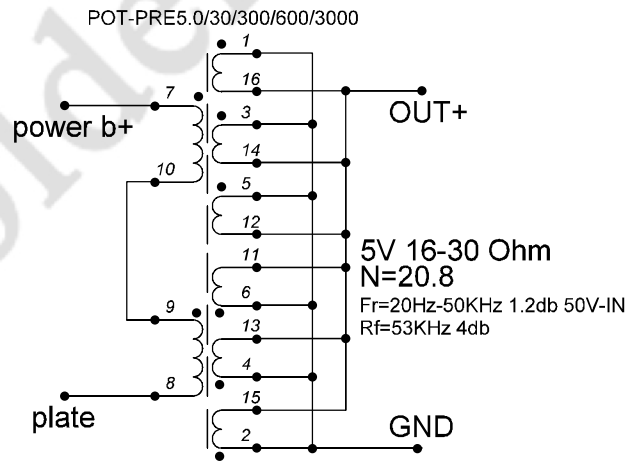

Description

**GOLDEN MIDDLE**

Schematic no.

**POT-PRE5.0/30/300/600/3000**

SPECIFICATIONS

CORE TYPE	EI 66X35 NM
CORE MATERIAL	165-35S M6 0.35mm
MODIFICATION	
DC VOLTAGE	

TECHNICAL

DCR1@20C	
DCI @100V	
L@50Hz	
L@1000Hz	

QC

PASS	
PASS	
PASS	
PASS	

Date

Name

Page no. **1**

Pages

Date